



ESA Messtechnik GmbH

Schlossstr. 119 - D-82140 Olching / München
 Telefon: +49 (0)8142 444 130 - Fax: +49 (0)8142 444 131
 Internet: www.esa-messtechnik.de
 E-Mail: info@esa-messtechnik.de

FORCE SENSOR CL 16U

FEATURES:

- High accuracy
- High stability and repeatability
- Tension and compression mode
- Thin profile
- Insensitive against out of alignment of force load
- Three year warranty and after sales service



This low-profile force sensor CL 16U is designed for measuring static and slow-changing forces. The sensor offers a wide range of applications in industrial process control and other professional force measurement projects.

The applied load is converted into an electrical signal by means of a metal spring element with a strain gauge full bridge. The bridge is fully balanced and temperature compensated.

The bridge is balanced and temperature compensated. Featuring a 350 Ω strain gauge full bridge circuit CL 16U is available in two configuration R1, R2 with a sensitivity of 1 mV/V or 2 mV/V respectively. For protection standard IP40 the sensor comes with an appropriate connector. For protection standard IP67 it is equipped with stuffing on the connection cable.

TECHNICAL SPECIFICATIONS:

Range	[kN]	1; 2; 5; 10; 20; 50; 100; 200; 500
Sensitivity	[mV/V]	1 - R1, 2 - R2
Accuracy	%	0,05 or 0,1 (referred to full scale)
Nominal supply voltage	[VDC]	10
Input resistance	[Ω]	Aluminium: 410 ±25, Steel: 380 ±25
Output resistance	[Ω]	350 + 5
Operating temperature range	[°C]	-20 to 100
Compensated temperature range	[°C]	20 to 90
Zero drift	[%/30 min]	≤ 0,03
Hysteresis after unloading from nominal load	[%]	≤ 0,03
Temperature effect on sensitivity	[%/10K]	≤ 0,05
Temperature effect on zero	[%/10K]	≤ 0,05
Maximum strain	[mm]	0,3
Overload	[%]	50
Isolation resistance	[GΩ]	≥40
Connectors		LUMBERG (Z1) or O-Ring gland (O1)
Protection system		IP40 or IP67
Dimensions		See drawing and table below
Spring element material		Aluminium or Steel
Cable length		3 m (standard) or other optional

Wiring Schematic for R1 / R2:

- | | |
|----------|-------------------|
| 1 brown | -W _y |
| 2 pink | 0 U _{zk} |
| 3 white | 0 U _z |
| 4 yellow | +U _z |
| 5 grey | +U _{zk} |
| 6 green | +W _y |
| 7 black | shield |

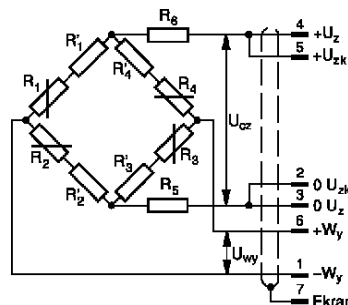

DIMENSIONS:

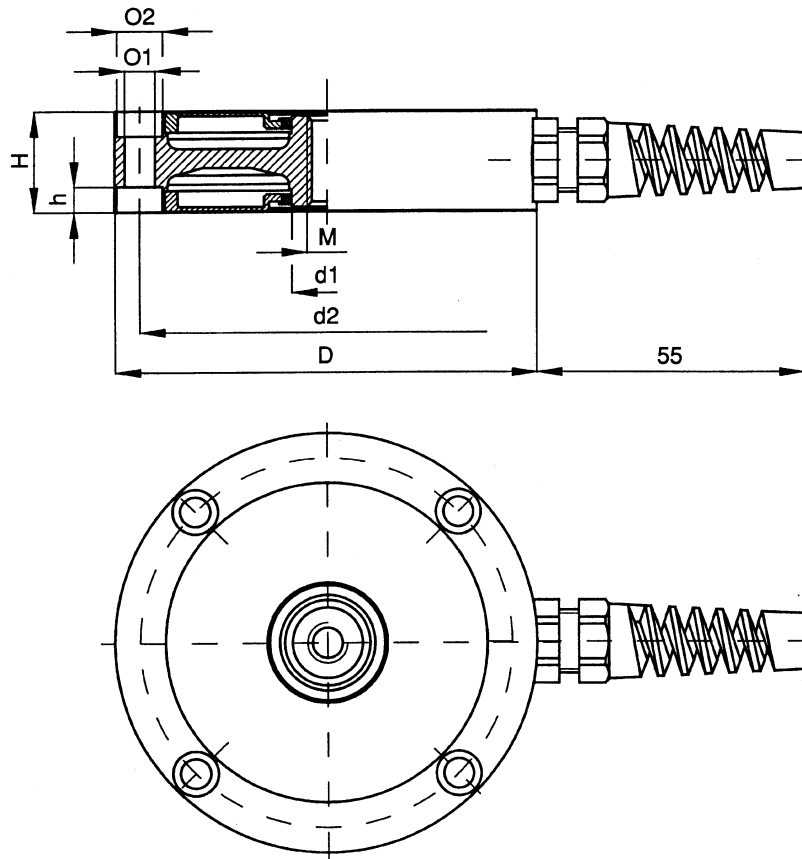

Range kN	D	H	M	d1	d2	O1	O2	h	Weight kg
	mm								
1	85	20	M8	13	74	6,2	9,5	5	0,35
2	85	20	M8	13	74	6,2	9,5	5	0,48
5	85	20	M8	13	74	6,2	9,5	5	0,50
10	125	28	M12	23	110	8,2	12	6	0,51
20	130	35	M24×2	40	110	10,2	17	10	0,77
50	130	35	M24×2	40	110	10,2	17	10	2,29
100	172	40	M36×3	57	145	12,2	19	12	4,60
200	188	60	M39×3	65	155	16,5	25	16	8,15
500	290	100	M72×4	113	235	20,5	39	20	26,00

ORDER INFORMATION:

CL16U-10 kN-0,1-R2-10-Z1-1

